



- Measurement length 1000 mm to 4800 mm
- 0,8 mm stainless steel wire diameter
- Maximum 42V Power Supply
- High strength stainless steel wire
- Potentiometric Measuring
Or 0-10 VDC Analog Output
Or 4-20 mA Current Output
- 0,5 m/s maximum speed
- IP54 Protection class
- Shock/Vibration resistant

The AWP series are wire potentiometric position transducers that turn a linear motion into a resistance variation. They are made of a precision rotating potentiometer operated by a winding or unwinding, stainless steel wire. Optionally other stroke lengths, cable length and socket connector can be requested.

TECHNICAL SPECIFICATIONS

Power Supply	Max. 42 V
Stroke Length (mm)	1000, 2000, 3000, 4000, 4800 (Please ask us for other)
Maximum Speed	0,5 m/s
Resistance	5K Ω (Optional Other)
Output	Potentiometric Or 0-10 VDC Analog Output Or 4-20 mA Current Output (Please ask us for other)
Linearity	\pm %0,25
Process Temperature	- 25 to +85 °C
Relative Humidity	%10 to %90
Protection Class	IP54
Weight	1000 grams

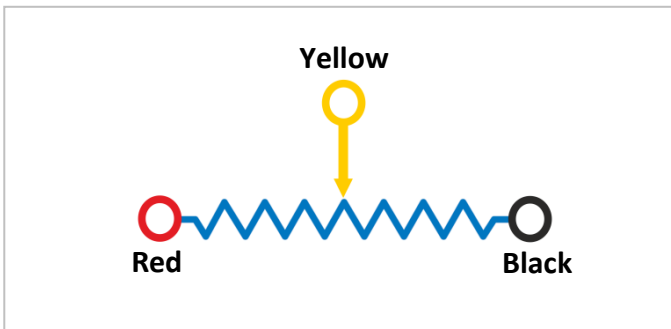

MECHANICAL DIMENSIONS

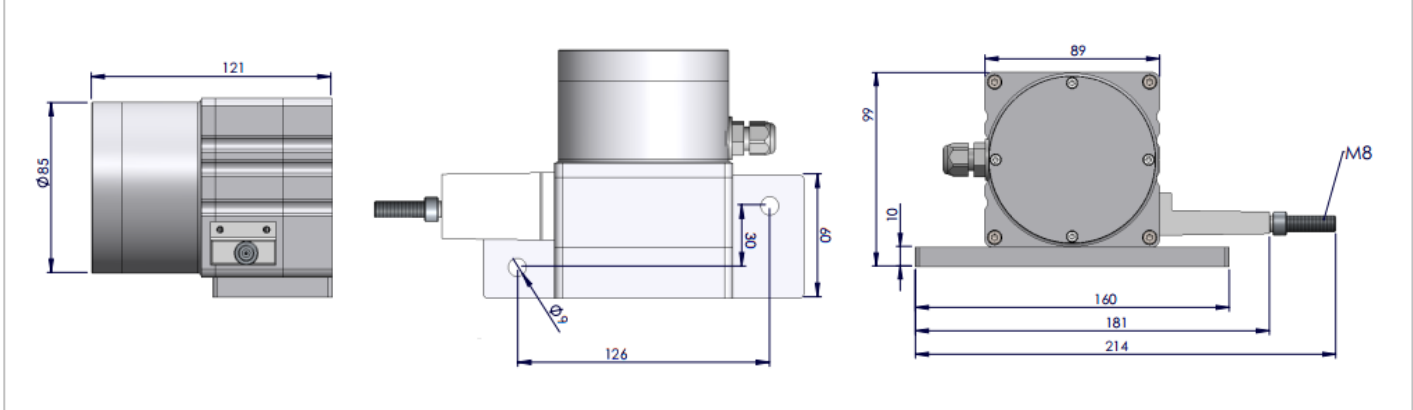

PRODUCT CODING

Model AWP 210	Resistance 5K : 5K Ω (Please ask us for other)	Output Signals No Code : Potentiometric V : 0-10 VDC Analog Voltage A : 4-20 mA Analog Current
AWP210	XXX Stroke Length See Stroke Length*	5K
		3M Cable Length 3M : 3M (standard) 5M : 5M 10M : 10M S16 : M16 Socket Connector S23 : M23 Socket Connector *Please ask us for other cable lengths and socket connectors
		X

*Stroke Length (mm):
1000, 2000, 3000, 4000, 4800 (Please ask us for other lengths)

1. Do not release the wire suddenly, after pulling.

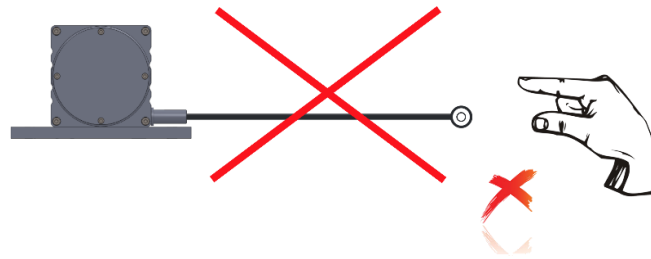

2. The wire encoder must be mounted vertically in position, not be horizontally.

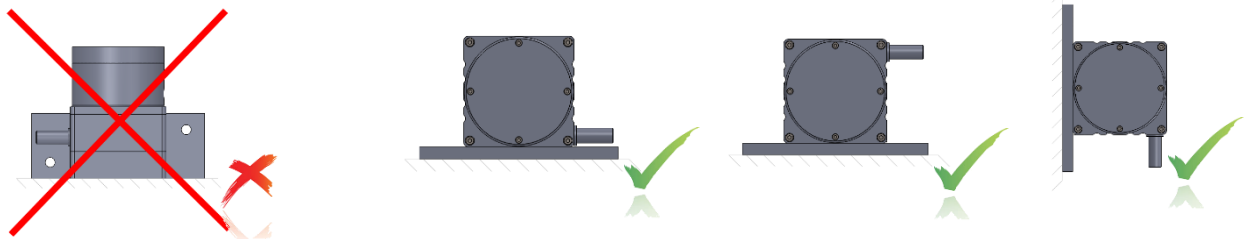

3. If there is a trickle of water (like a rain), the wire outlet must not be a drip of water upstream. If needed please use guide rollers.

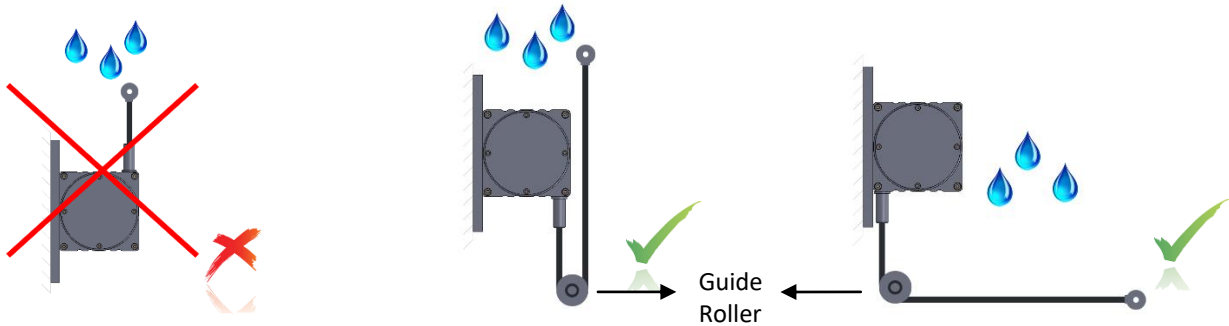

4. The wire should not be pulled in angular. If needed, please use guide rollers.

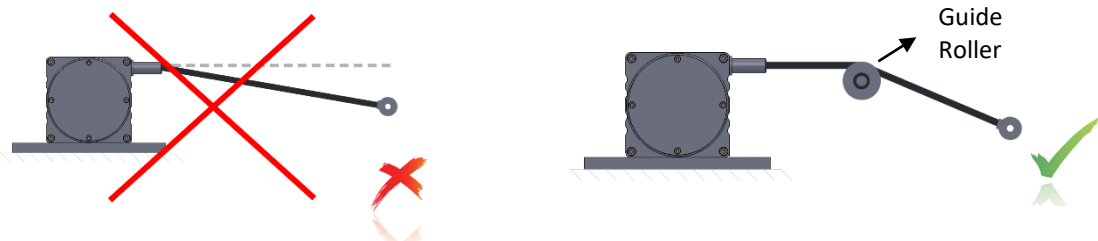

Failure to comply with these recommendations, the malfunctions that may occur will not be under the warranty.